

Part #: PT413-21140

Conflicts: P/N PTR11-21100 Lowering Springs (CA only)

Kit Contents:

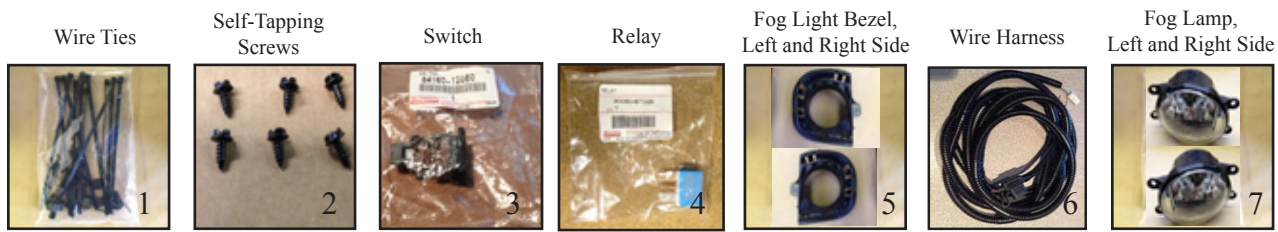

Hardware Content

Item#	Quantity Reqd.	Description
1	11	7.5 inch Wire Ties Black
2	6	#10-16 Hex Head Self-Tapping Screws
3	1	Switch
4	1	Relay
5	2	Fog Light Bezel, Right and Left
6	1	Wire Harness
7	2	Fog Lamp, Right and Left

Additional Items (may be required)

Item#	Quantity Reqd.	Description

Recommended Sequence of Application

Item#	Accessory	Description
1	Fog Light Kit	
2	v4	
3	v5	
4	Audio	

General Applicability

--

Recommended Tools

Personal & Vehicle Protection	
Blankets	
Special Tools	
Hella Photometric Beam Setter (or equivalent)	
Panel Removal Tool	
Installation Tools	
Socket Wrench	
10 mm Socket	
Socket Extension	
Torque Wrench	Capable of measuring 5.4 N·m (48 in·lbs)
Diagonal Cutters	
#2 Phillips Screwdriver	
8 mm socket or nut driver	
Special Chemicals	

Legend

- STOP:** Damage to the vehicle may occur. Do not proceed until process has been complied with.
- CAUTION:** A process that must be carefully observed in order to reduce the risk of damage to the accessory/vehicle.
- OPERATOR SAFETY:** Use caution to avoid risk of injury.
- TOOLS & EQUIPMENT:** Used in Figures to call out the specific tools and equipment recommended for the process.
- REVISION MARK:** This mark highlights a change in installation with respect to previous issue.
- SAFETY TORQUE:** This mark indicates that torque is related to safety.
- VIDEO:** Video Available; click to Play

Table of Contents

I. Preparation 1-2
 1. Table Of Contents.....2
 II. Procedure.....3-15
 1. Vehicle Preparation.....3
 III. Accessory Function Checks.....16
 1. Vehicle Function Checks.....16

Accessory Installation Practice (read before installation)

Care must be taken when installing this accessory to ensure damage does not occur to the vehicle. The installation of this accessory should follow approved guidelines to ensure a quality installation.

These guidelines can be found in the “Accessory Installation Practices” document.

This document covers such items as:

- Vehicle Protection (use of covers and blankets, cleaning chemicals, etc.)
- Safety (eye protection, checking torque procedure, etc.)
- Vehicle Disassembly/Reassembly (panel removal, part storage, etc.)
- Electrical Component Disassembly/Reassembly (battery disconnection, connector removal, etc.)

Please see your Toyota/Scion/Lexus dealer for a copy of this document.

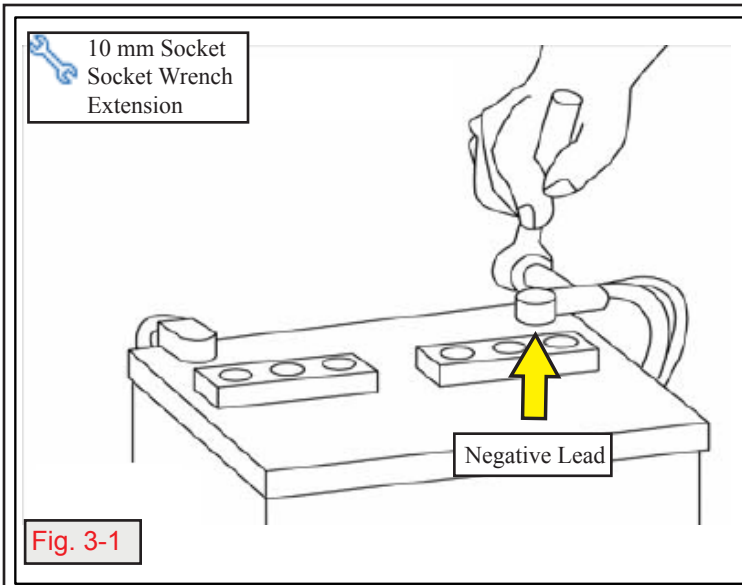

1. Precautions

- +** a. Engine components and coolant may be hot, use caution.

2. Check Kit Contents

- STOP** a. Check kit for content and damage.

3. Vehicle Preparation

- a. Protect fender before starting.
- +** b. Remove battery cable from negative terminal (Fig. 3-1).
- +** CAUTION: Do not touch the positive terminal with any tool during removal.

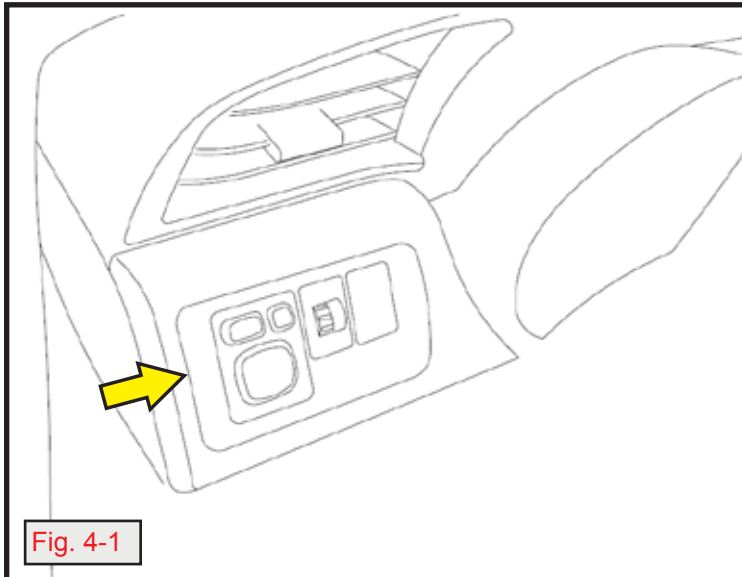

4. Switch Installation

- a. With the aid of a panel removal tool, detach mirror control panel (Fig. 4-1).

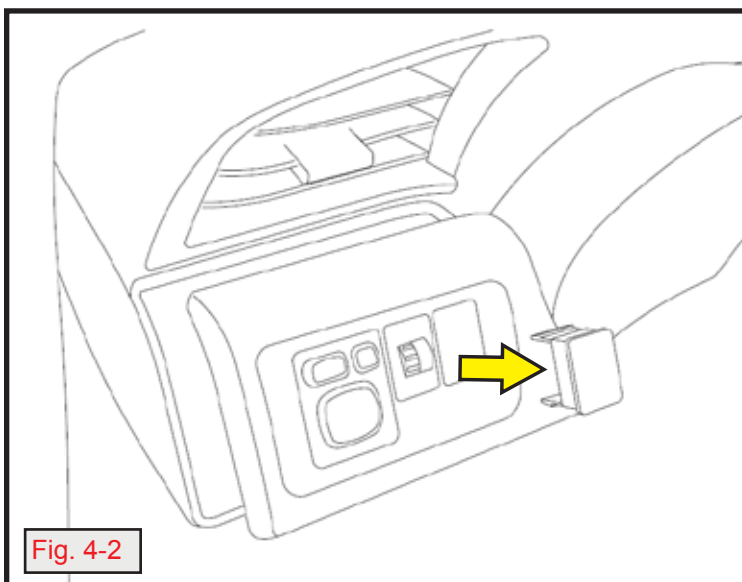

- b. Disconnect connectors.
- c. Remove right knock out from this panel (Fig. 4-2).

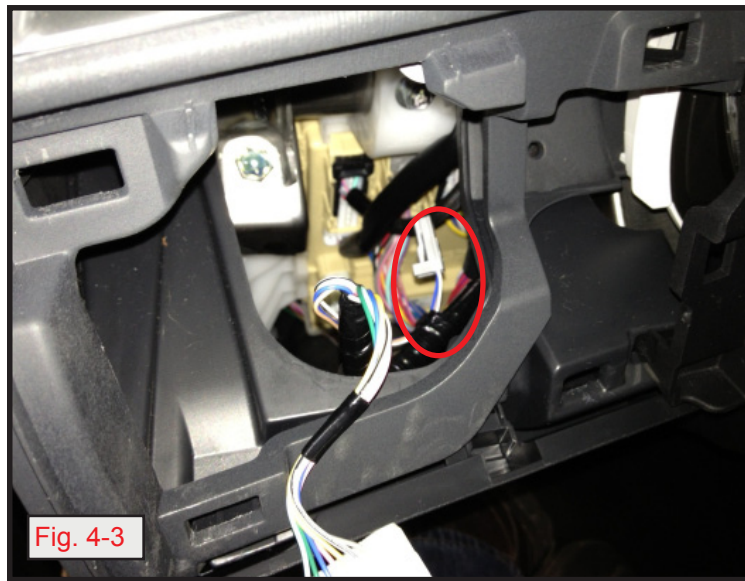

- d. Find 4 pin connector inside of instrument panel and remove electrical tape (Fig. 4-3).

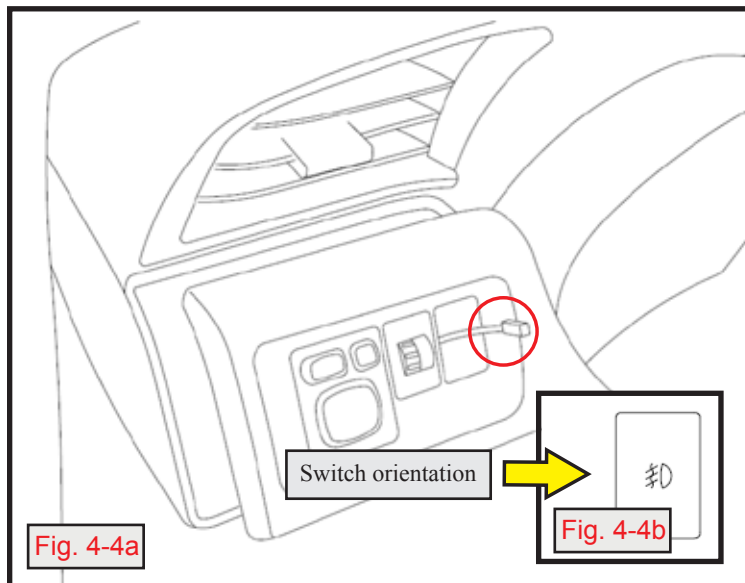

- e. Install switch by pushing it into the opening in the mirror control panel (Fig. 4-4a).

⚠ CAUTION: Make sure that the graphic is in the indicated orientation (Fig. 4-4b).

- f. Reconnect mirror, dimmer, and fog light switch.
- g. Reinstall mirror control panel.

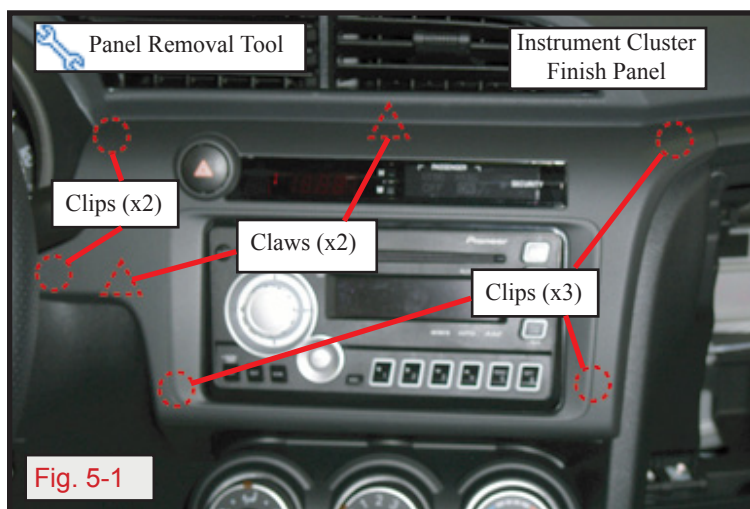

5. Relay Installation

- a. Remove the head unit.
 - 1. Disengage the five (5) clips and two (2) claws and then remove the instrument cluster finish panel. Make sure to disconnect the electrical harness at the top of the panel (Fig. 5-1).

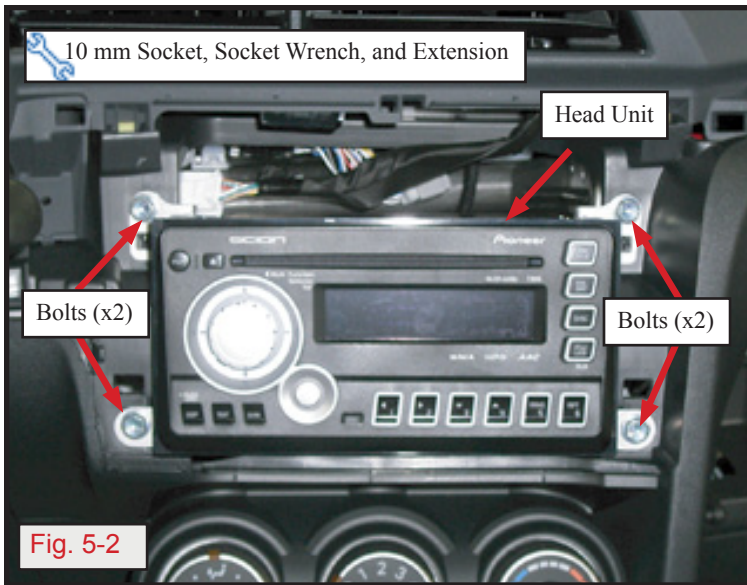

2. Remove the four (4) bolts and the head unit (Fig. 5-2).

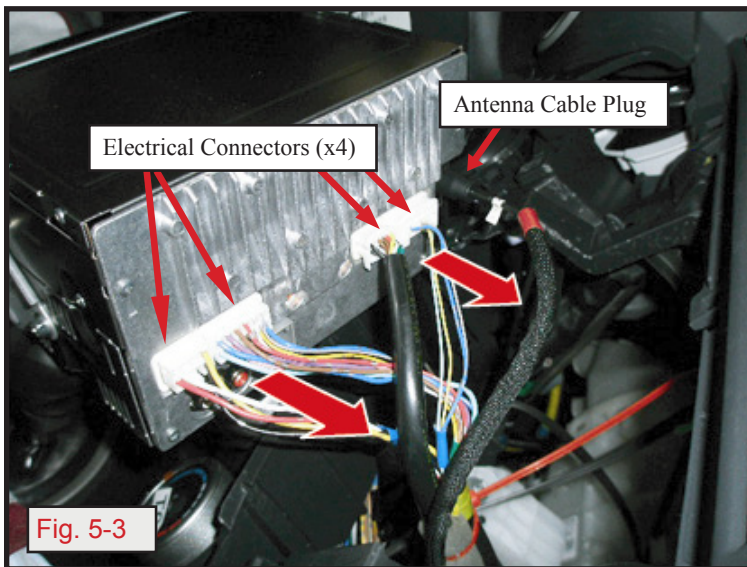

- b. Disconnect all electrical connectors and antenna cable plug from the rear of the head unit (Fig. 5-3).
- c. Remove the head unit from the vehicle.

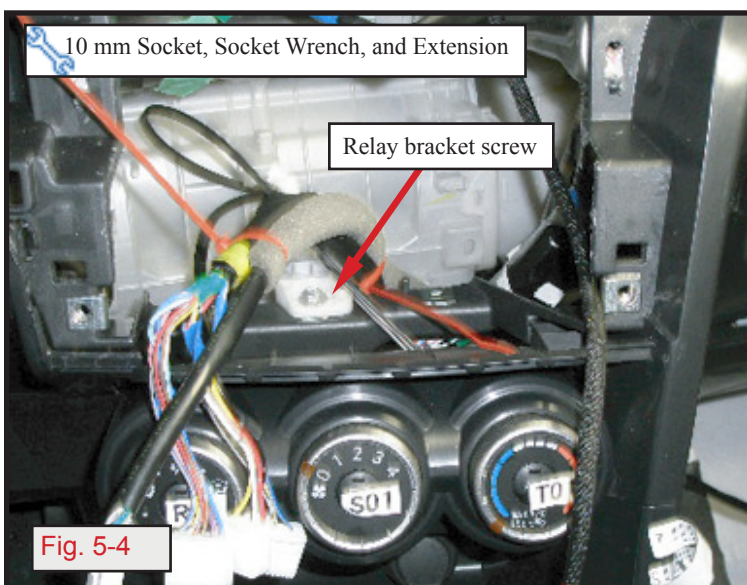

d. Loosen the screw holding the relay bracket (Fig. 5-4).

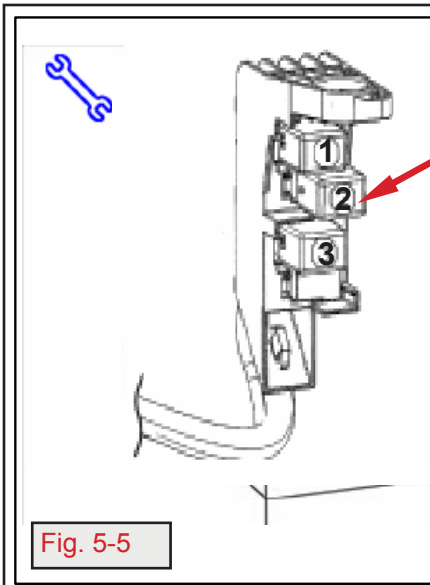

- e. Raise the bracket up and install the relay in middle port (Second port down from the top, Fig. 5-5).
- f. Reattach the relay bracket, reattach the wiring to the head unit, and then reinstall the head unit.
- g. Reassemble the dash panel (Fig. 5-1).

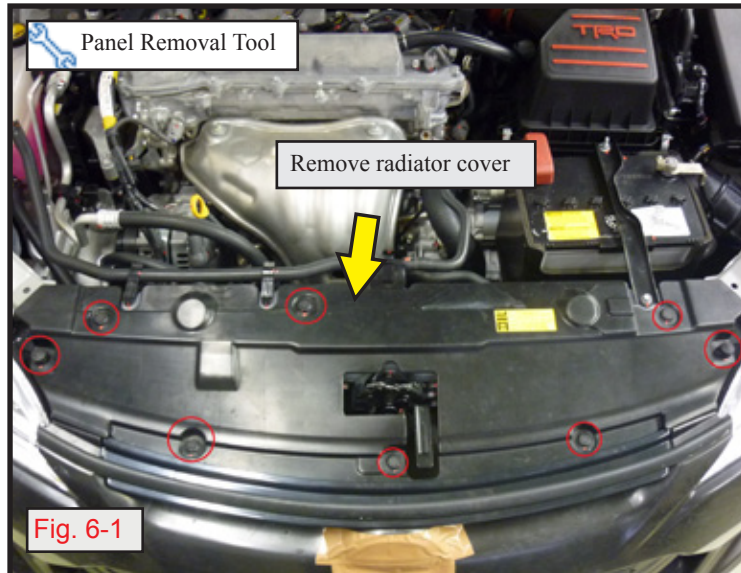

6. Installation of Wire Harness

- a. Remove the radiator cover (Fig. 6-1).
 - 1. Using panel removal tool, remove six (6) attachment pins and two (2) bumpers.



- 2. Lay the harness over the top of the engine. Route the short end of the harness with the 2-pin connector down through the opening near the driver side of the battery (Fig. 6-2 and Fig. 6-3 on Page 7).

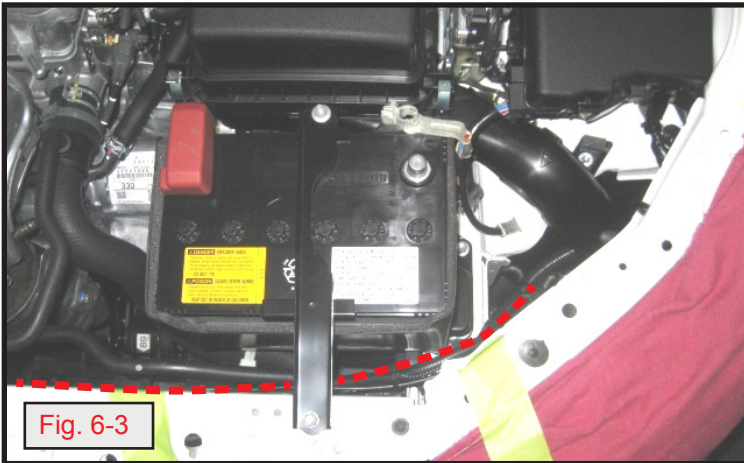

b. Route the harness as shown (Fig. 6-3).

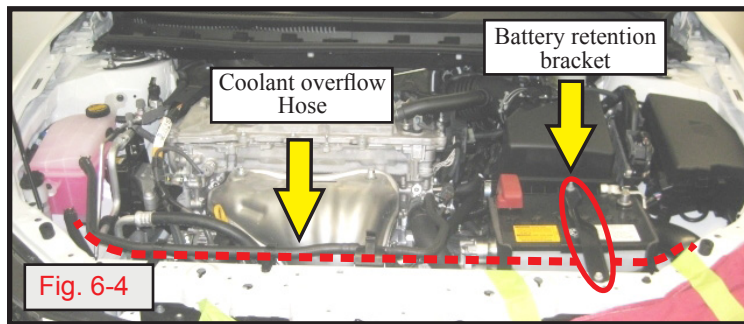

c. Route the long end of the harness towards the passenger side of the vehicle underneath the battery retention bracket and coolant overflow hose (Fig. 6-4).

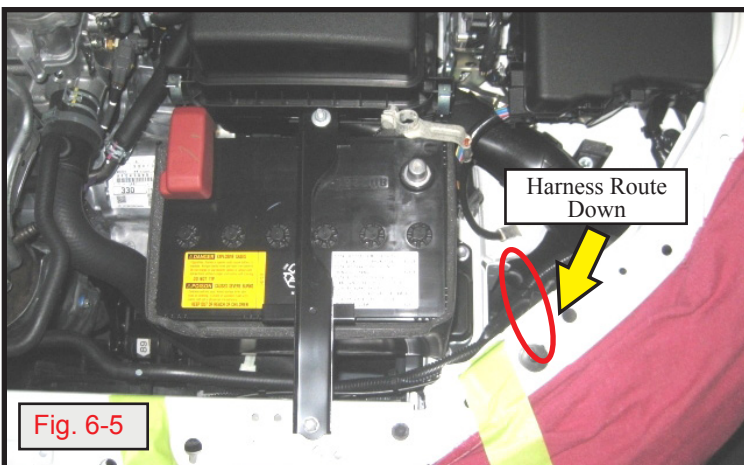

d. Route the harness with the single-pin connector down beside battery (Fig. 6-5).

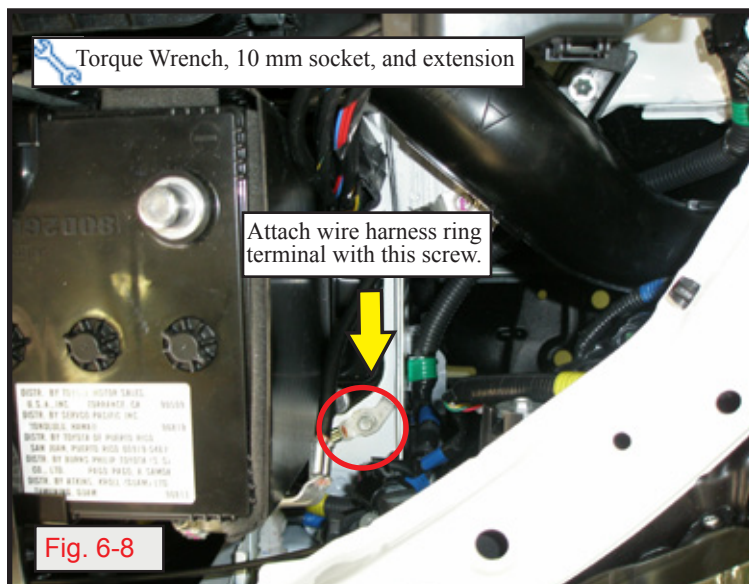
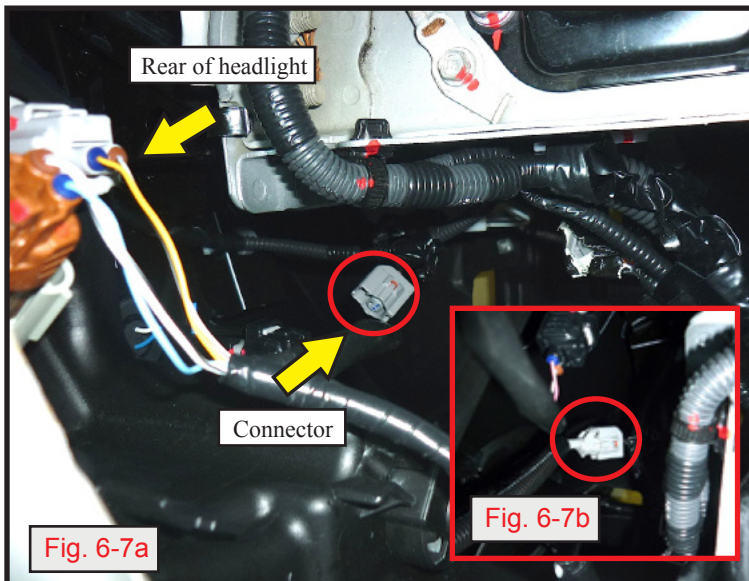
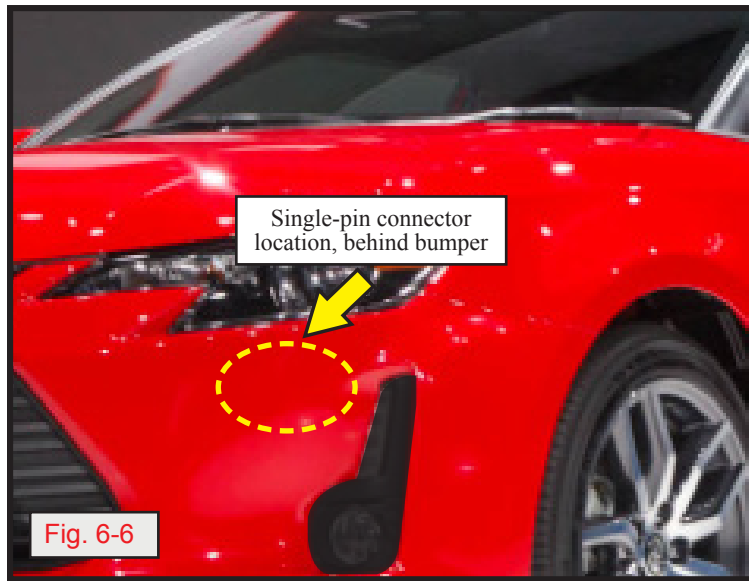

- e. Locate the vehicle single-pin black connector behind the bumper, below and in front of the battery. Connect the fog light connector to the vehicles' single-pin black connector (Fig 6-6).
- 1. Breakaway tape may need to be removed from the connector before use.
- f. Locate the single-pin harness connector (vehicle side connector may be black (Fig. 6-7a).
- g. Plug in the harness as shown (Fig. 6-7b).
- h. Locate the grounding screw near the battery. Remove the screw, add the wire harness ring terminal (ground) and reinstall the screw through both terminals (Fig. 6-8).
- i. Tighten to **5.4 N·m (48 in·lbs)**.

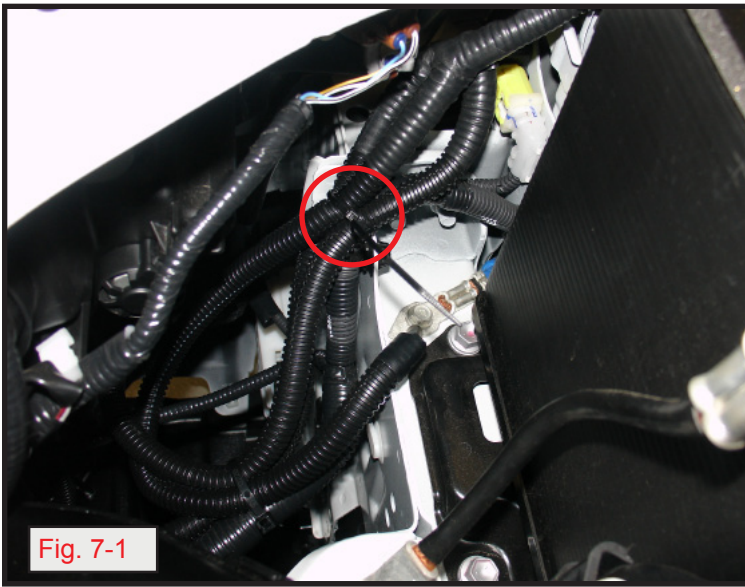

Fig. 7-1

7. Wire Management

⚠ NOTE: Install all wire ties so that when they are trimmed they will not cut, pierce, or otherwise damage existing components. The latching end of the wire tie should be kept away from hoses and wiring.

⚠ NOTE: Do not tighten wire ties until the entire harness is in place to have correct slack.

a. Apply one (1) wire tie behind the left headlight to secure all three (3) fog light harness branches to the vehicle ground harness as shown (Fig. 7-1).

b. At the front of the battery, secure the wire harness to the hood-latch cable with two (2) wire ties as shown (Fig 7-2).

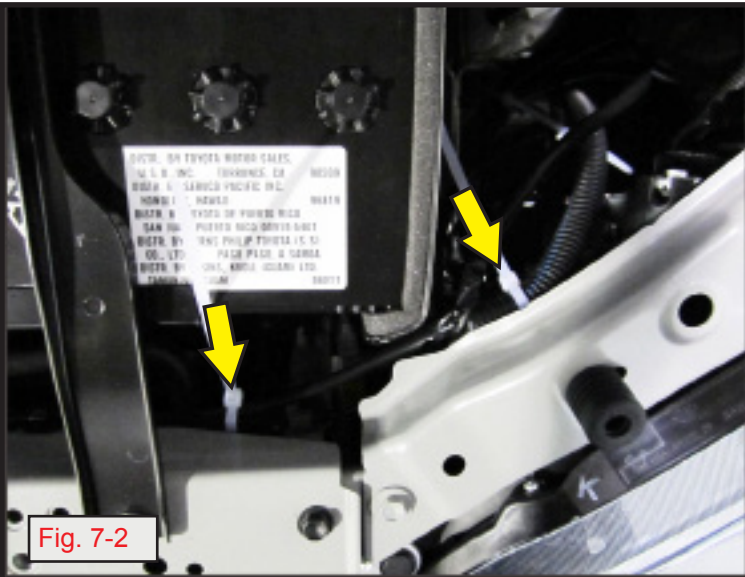

Fig. 7-2

c. Locate the hole in the horizontal support as shown. Route the wire tie through this hole and out the hole hidden under support (Fig 7-3).

1. Do not attach to the hood latch cable at this point.

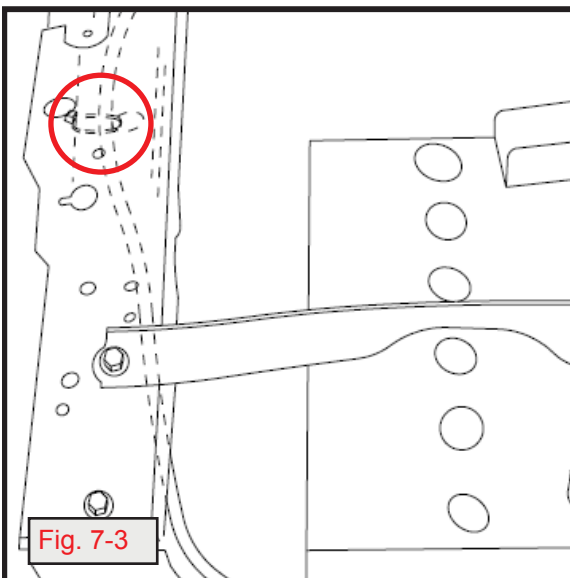
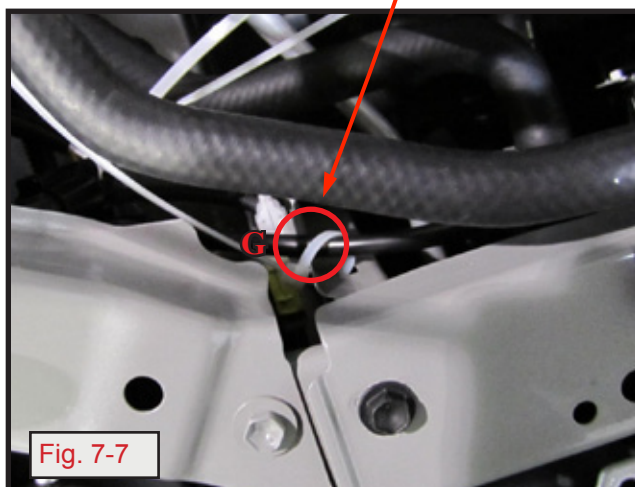
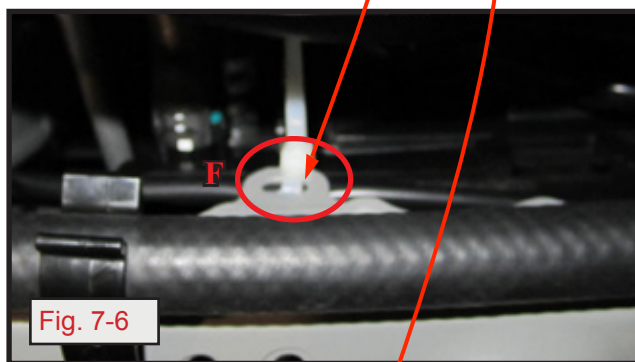
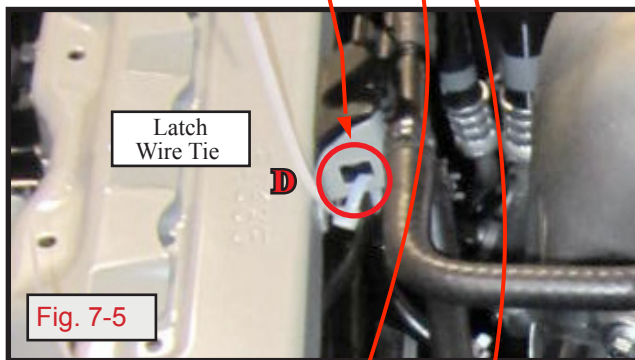
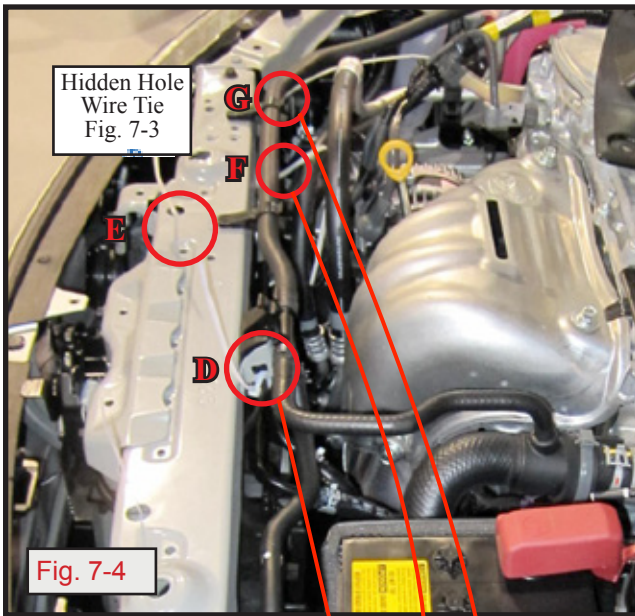

Fig. 7-3



- d. Loop the wire tie through one opening in the hood latch bracket and secure wire harness (Fig. 7-4 and Fig. 7-5).
- e. Use the visible and hidden holes in the horizontal support to secure the wire harness (Fig. 7-4).

- f. Locate the hole in vertical surface of support, under the coolant overflow hose. Secure the wire harness to this hole (Fig. 7-6).
 - 1. Keep the harness under the horizontal support.

- g. Locate the hole in vertical support. Secure the wire harness to this hole (Fig. 7-7).

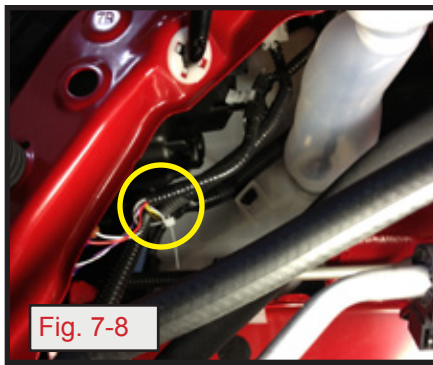

- h. Route the remaining 2-pin connector through the opening under the passenger (vehicle right) side headlight (Fig 7-8).

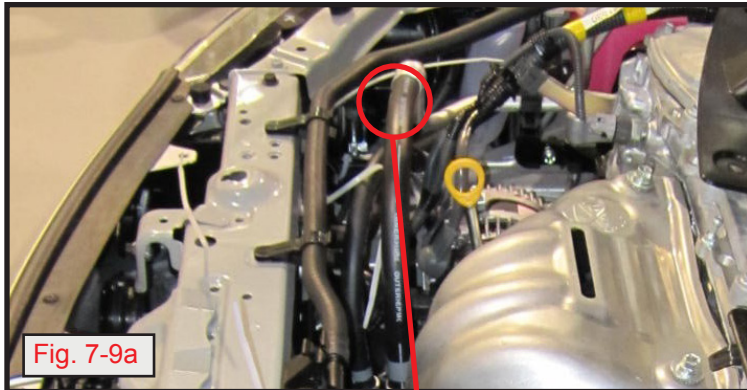

- i. Locate the corrugated tubing under the passenger side headlight wire harness (Fig. 7-9a).

- 1. Do not attach anything to the airbag wire harness (Fig. 7-9b).

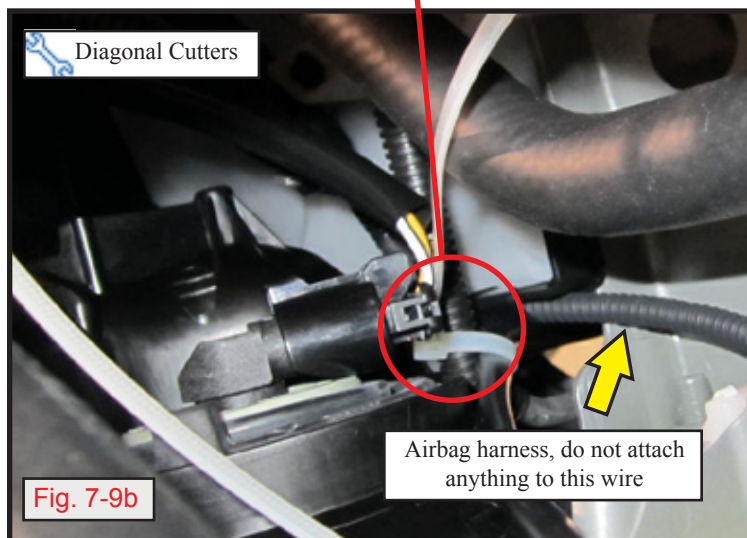

⚠ CAUTION: Verify there is enough length on the passenger side to connect to fog light. Adjust harness if necessary.

- j. Tighten all wire ties.

+ 1. Cut off all excess wire ties. Keep sharp ends to a minimum.

- k. Reinstall the radiator cover removed in Step 6(a) (Fig. 6-1).

8. Exterior Parts Removal

- a. Raise the vehicle.
- b. Remove the engine under-cover by removing the ten (10) fasteners that are circled (Fig. 8-1).

- 1. Save all screws, clips, and the under-cover.

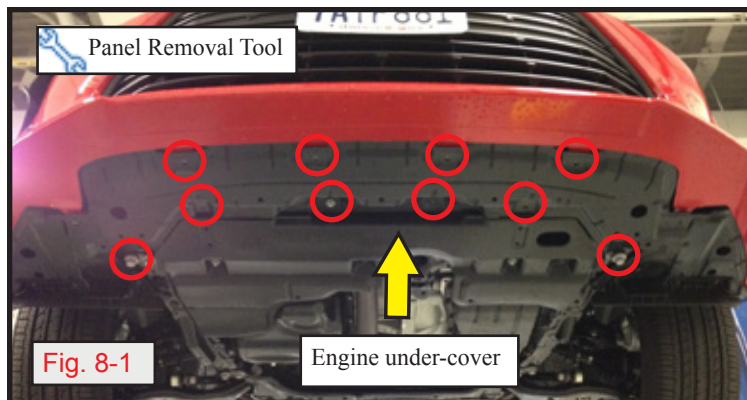

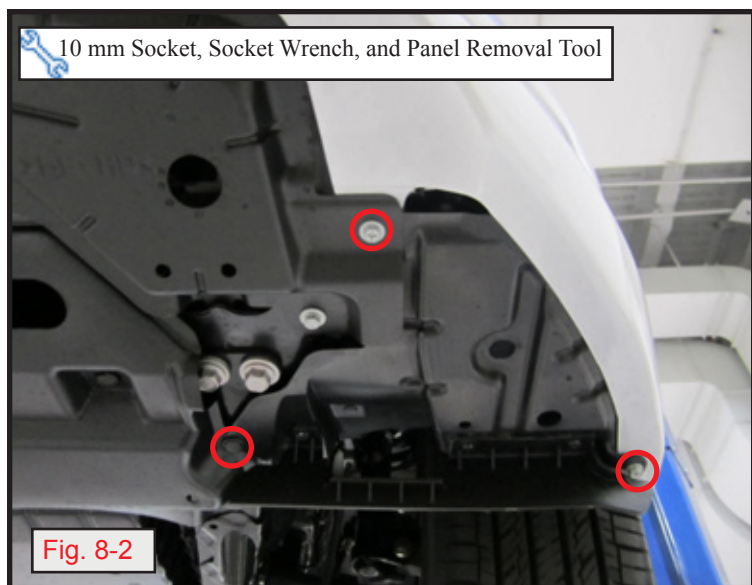

- c. Remove the two (2) screws and one (1) snap-fastener circled from fender liner (Fig. 8-2).
- d. Repeat for other side of vehicle.

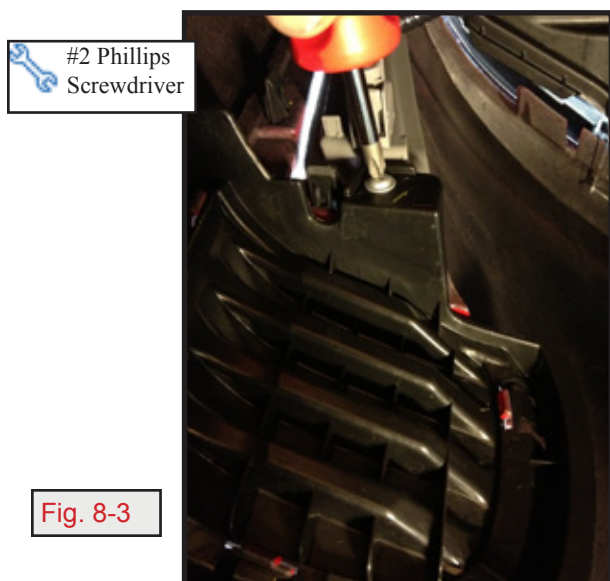

- 1. Remove one (1) fastener from the fog light filler plate located behind the bumper cover (Fig. 8-3).



- e. Push the bezel out from the rear (Fig. 8-4).

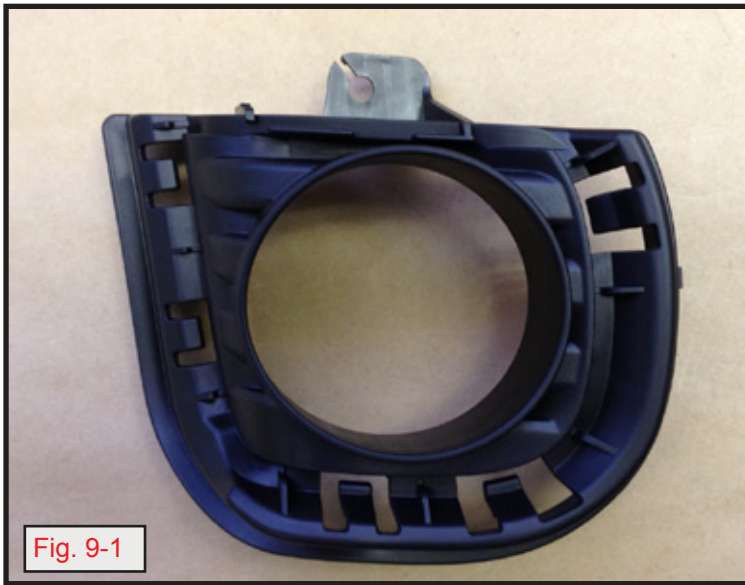

9. Assemble Fog Light

- a. Assemble the left and right fog lights.
- b. Bezels are marked for installation on the left and right side of the vehicle (Fig. 9-1).

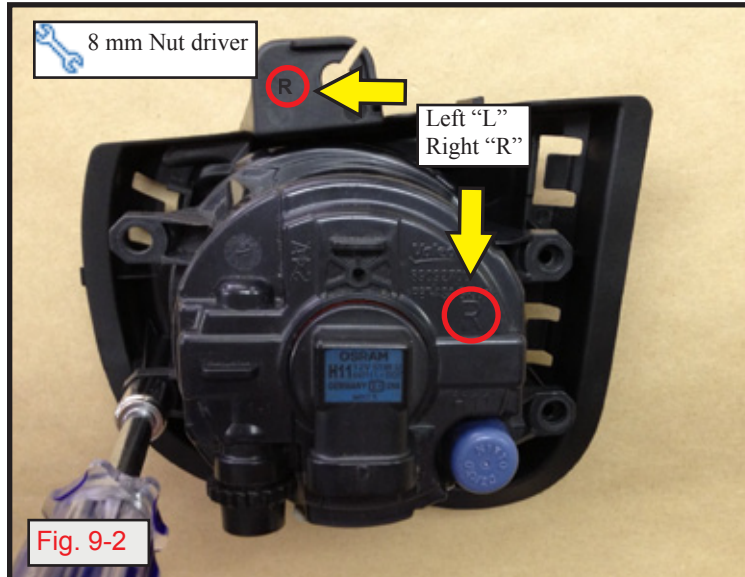

- c. Secure the lamp to bezel.
 1. Install the lamps by inserting them from the rear of the bezel (Fig. 9-2).
 2. Use three (3) #10-16 hex head self-tapping screws to fasten the lamp to the bezel.

⚠ CAUTION: Lamps are marked RIGHT and LEFT and will not fit if reversed.

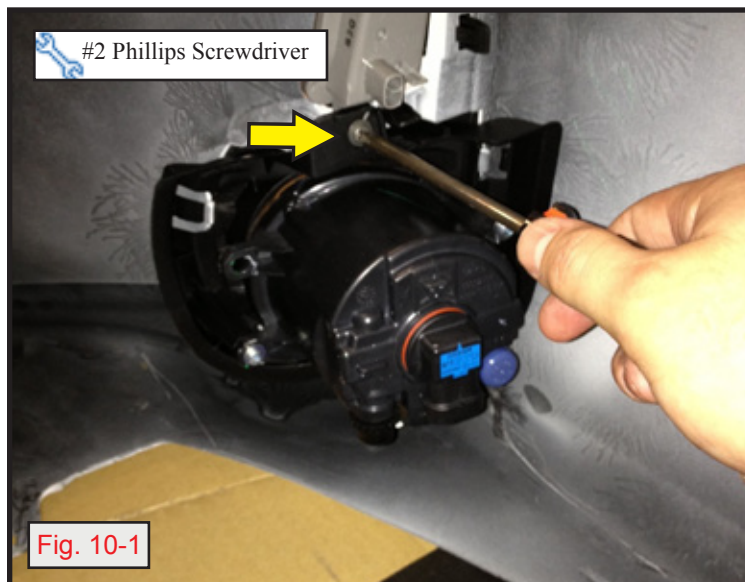

10. Secure Fog Light Assembly to vehicle.

- a. Reinstall the lamp and bezel in the bumper cover. Make sure all bezel clips engage properly (Fig. 10-1).

⚠ CAUTION: Do not overtighten the screw, do not use power tools.

- b. Connect the harness to the lamp.
- c. Repeat for the other side of the vehicle.

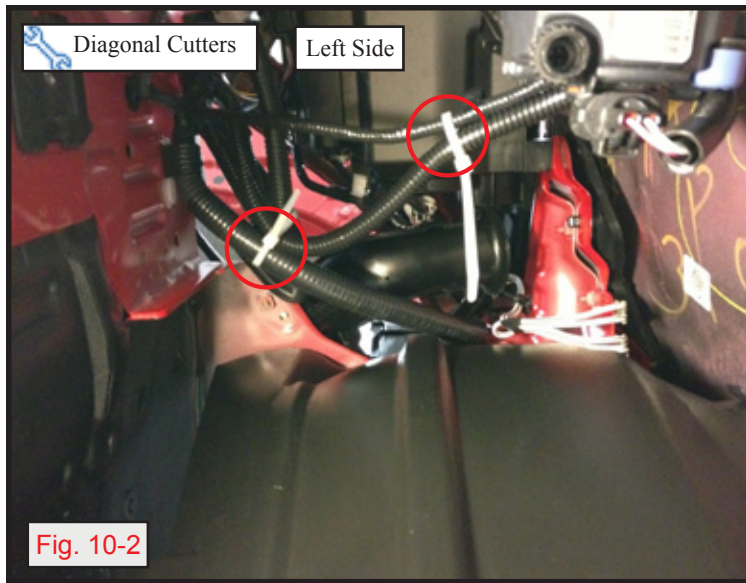

- d. Secure the left side harness using two (2) wire ties to secure the harness as indicated by the circles (Fig. 10-2).

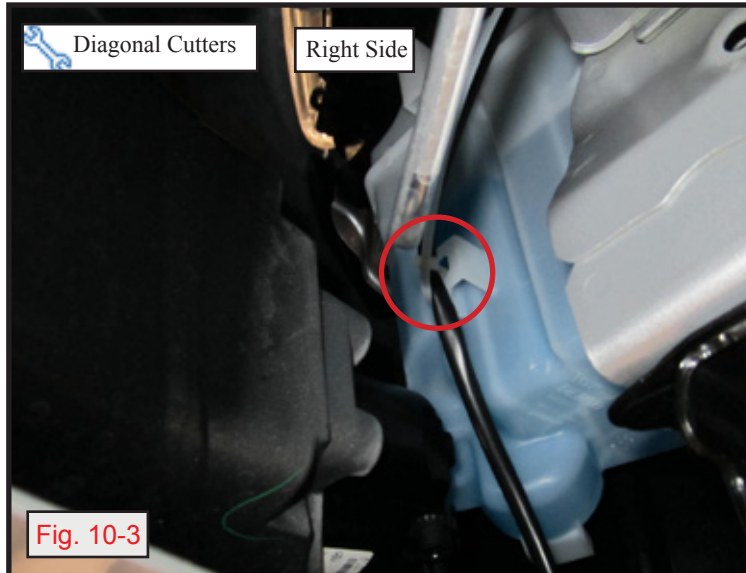

- e. Locate the mounting hole on the windshield washer fluid reservoir above and behind the passenger side fog lamp. Use one (1) wire tie to secure the harness to this mounting hole (Fig 10-3).

-  f. Trim off all excess from wire ties. Keep sharp ends to a minimum.

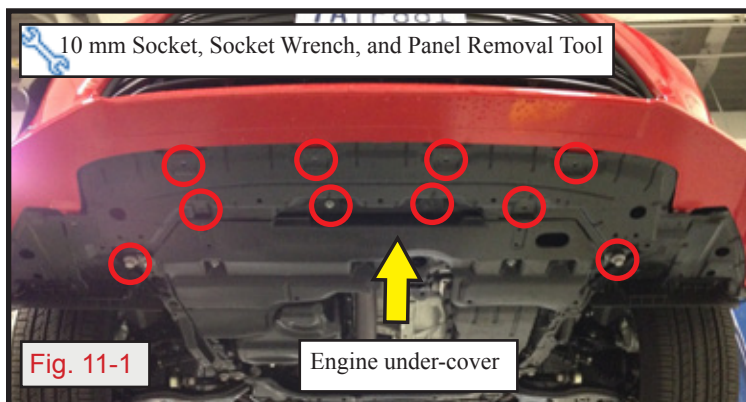

11. Reassembly

- a. Reinstall the engine under-cover (Fig. 11-1).



NOTE: If this is a DIO installation, wait until the end of installation, after aiming (Step 12).

- b. Reinstall the ten (10) fasteners securing the engine under-cover in locations that are circled.

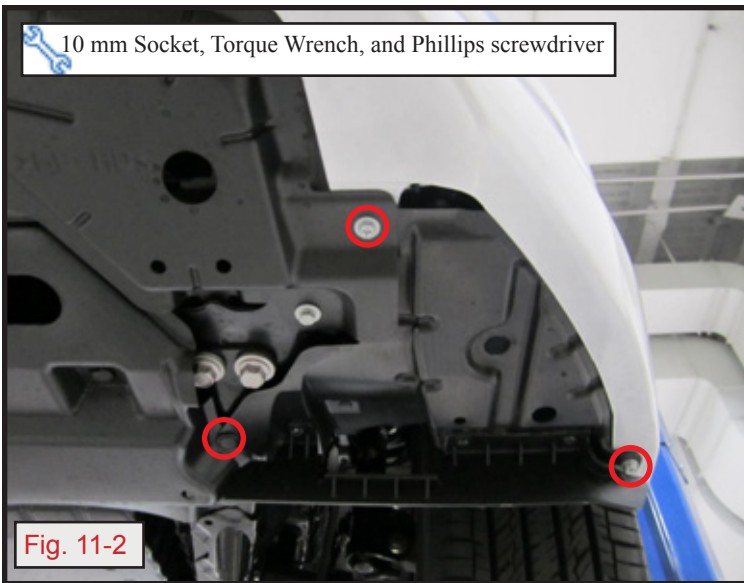

c. Reinstall the two (2) screws and one (1) snap-fastener circled from fender liner (Fig. 11-2).

1. Repeat for other side of vehicle.

d. Lower the vehicle.

e. Reconnect the battery negative cable.



f. Tighten to 5.4 N·m (48 in·lbs).

CAUTION: Do not touch the positive terminal with any tool during replacement.

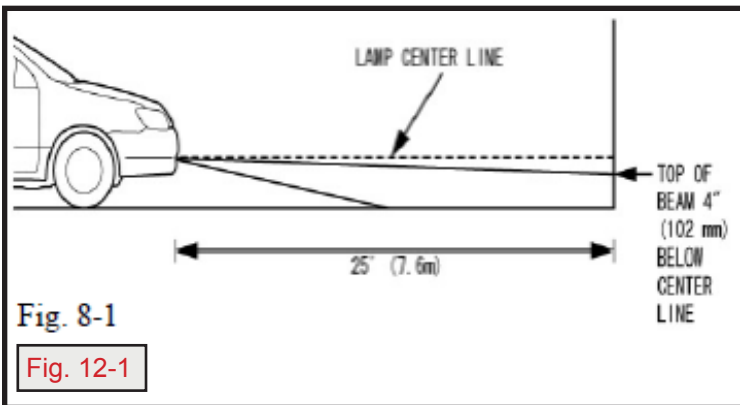

12. Aiming Instructions (DIO Only)

a. Position the vehicle on a flat surface at a distance of 25 feet (7.6m) from the fog light to a wall (Fig. 12-1).

1. Measure the distance from the center of the lamp to the ground and mark off the same height on the wall. This is your fog light centerline.

2. Adjustment of the fog lights is done by turning the adjustment screw using a Phillips screwdriver.

3. Turn on the fog lights and adjust them so that the top of the beam (high intensity portion) falls 4 inches (102 mm) below the mark on the wall (fog light centerline).

b. Alternate aiming method: Use Hella Photometric Beam Setter (or equivalent) to correctly align fog light beam (Fig 12-2).

c. Reinstall the vehicle under-cover following Step 11a on Page 14

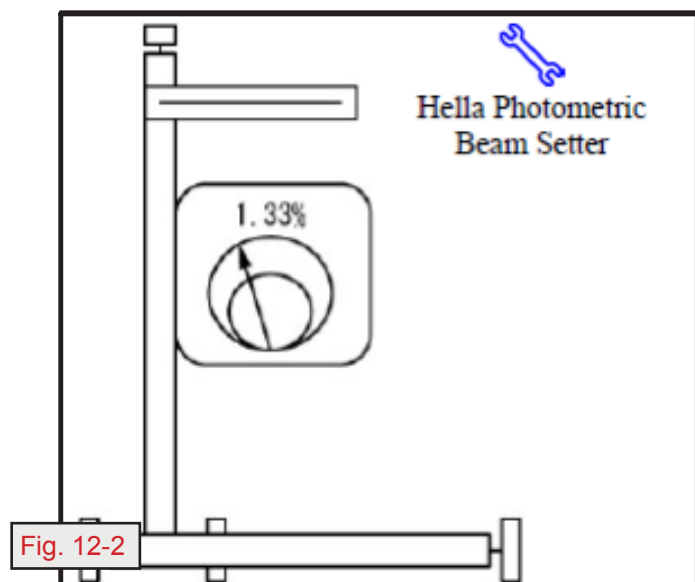

CHECKLIST – these points **MUST** be checked to ensure a quality installation.

Accessory Function Checks

Major Action Checks

	What to do.	What to look for.
1	Turn on headlights	Headlights “ON”
2	Turn on fog lights	Fog lights “ON”
3	Turn off headlights	Fog lights are not “ON” with headlights “OFF”
4	Check fog light switch orientation	Lamp symbol is facing left
5	Switch on high beams	High beams “ON” / Fog lights “OFF”
6	Check dashboard lights	Low beams “ON” / Fog lights “ON”
7	Inspect bolt torque	Battery negative cable: 5.4 N·m (48 in·lbs)

Vehicle Function Check

	Function		Function
<input type="checkbox"/>	Check taillights.	<input type="checkbox"/>	Check reverse lights.
<input type="checkbox"/>	Check brake lights.	<input type="checkbox"/>	Check emergency flashers.
<input type="checkbox"/>	Check turn signals.	<input type="checkbox"/>	Check mirror controls.
<input type="checkbox"/>	Check battery terminals for tightness with 10 mm socket and torque wrench.	<input type="checkbox"/>	Check Radio.

Vehicle Appearance Check

<input type="checkbox"/>	Verify fit of fog lamps		
<input type="checkbox"/>	Verify fit of bezels		
<input type="checkbox"/>	Verify fit of switch		
<input type="checkbox"/>	After accessory installation and removal of protective cover(s), perform a visual inspection of the vehicle		Ensure no damage (including scuffs and scratches) was caused during the installation process. (For PPO installations, refer to TMS Accessory Quality Shipping Standard.)